

# WR-T2T3-AC

For installation at LPZ 0<sub>c</sub>-1 or higher, protecting low voltage devices from surge damages, mainly used in power supply system such as power distribution-room, distribution-cabinet and other important power supply system.

Applied in pluggable SPD Class II(Class C)for various power supply system.

Designed according to IEC 61643-1/GB 18802.1.

- Standard single chip structure, pluggable
- Consist of varistor and thermal disconnection device
- High discharge capacity, quick response
- Double thermal disconnection devices, provide more reliable protection
- Multifunctional terminals for connection of conductors and busbars
- Green window will change when fault occurs, also provide remote alarm terminal at the same time



Type	WR-T2T3-AC	
Rated voltage (max.continuous a.c.voltage) [ U <sub>c</sub> ]	275V or 385V	
Nominal discharge current (8/20) [ I <sub>n</sub> ]	10kA	
Maximum discharge current [ I <sub>max</sub> ]	40kA	
Voltage protection level [ U <sub>p</sub> ]	≤1.5kV	
Response time [ t <sub>λ</sub> ]	≤25ns	≤25ns
Max. backup fuse	125A gL/gG	125A gL/gG
Operating temperature range [ T <sub>o</sub> ]	-40°C...+80°C	-40°C...+80°C
Cross-sectional area	1.5mm <sup>2</sup> ~ 25mm <sup>2</sup> solid / 35mm <sup>2</sup> flexible	
Mounting on	35mm DIN rail	
Enclosure material	Purple (module) / light gray (base) thermoplastic, UL94-V0	
Dimension	1 mod	
Test standards	IEC 61643-1; GB 18802.1; YD/T 1235.1	
Certification	CE ROHS ISO9001 CQC TUV	
Type of remote signalling contact	Switching contact	
Switching capacity a.c.	250V/0.5A	
Switching capacity d.c.	250V/0.1A; 125V/0.2A; 75V/0.5A	
Cross-sectional area for remote signalling contact	Max. 1.5mm <sup>2</sup> solid/flexible	

Type	WR-T2T3-AC	
Packing unit	4pc(s)	
Weight	120g	

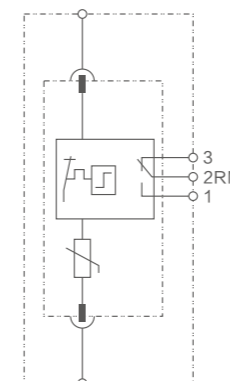

WR-T2T3-AC Basic circuit diagram

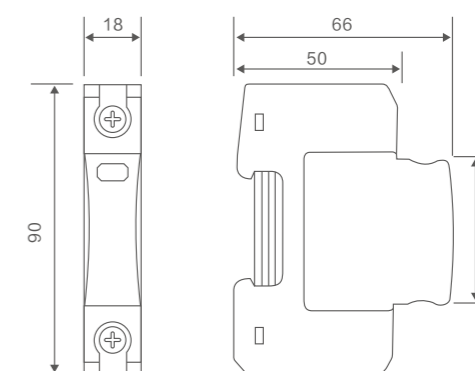

WR-T2T3-AC Dimension diagram



WR-T2T3-AC/2P

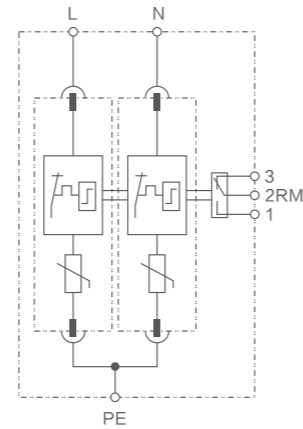

Type	WR-T2T3-AC/2P
Packing unit	2pc(s)
Weight	203g



WR-T2T3-AC/1+NPE

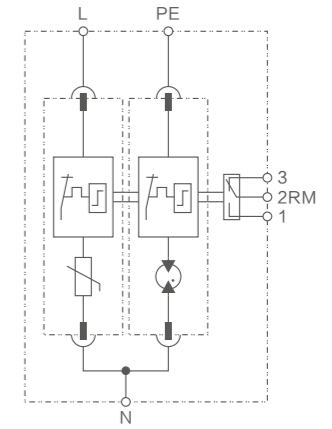

Type	WR-T2T3-AC/1+NPE
Packing unit	2pc(s)
Weight	211g



WR-T2T3-AC/3P

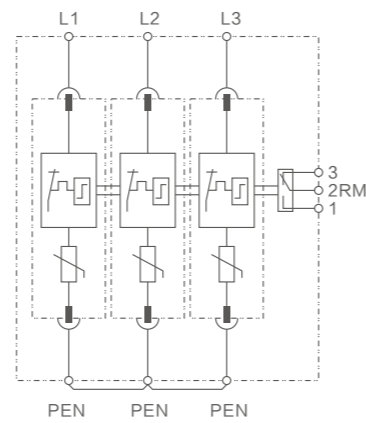

Type	WR-T2T3-AC/3P
Packing unit	1pc(s)
Weight	295g



WR-T2T3-AC/3+NPE

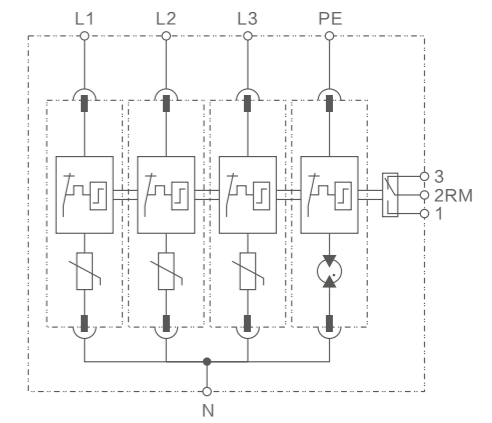

Type	WR-T2T3-AC/3+NPE
Packing unit	1pc(s)
Weight	392g



WR-T2T3-AC/4P

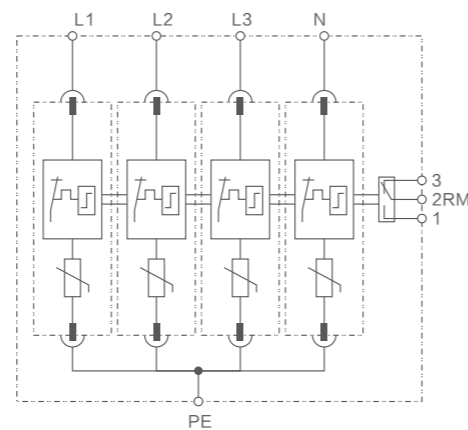

Type	WR-T2T3-AC/4P
Packing unit	1pc(s)
Weight	381g